

DEVELOPMENT OF A MINITYPE PRECISE SPINDLE SYSTEM FOR DIAMOND LAPPING & POLISHING*

Fu Huinan, Chen Dongsheng and Zhao Yong

Department of Mechanical Engineering, GuangDong University of Technology, China

Abstract: In order to develop a system which can machine precisely and stably in the process of diamond lapping and polishing, a minitype precise spindle system is designed in this paper. In such minitype spindle system, the brushless DC spindle motors are used which is built with fluid dynamic bearings, and experimental results show that the spindle system is reliable and stable for diamond polishing. Tests by the AFM show that the surfaces of diamond edge's Ra is 6.725nm and whole diamond average Ra is 3.25nm.

Keywords: *Diamond tools, Lapping & Polishing, Spindle System*

1. Introduction

Recently, a great deal of nonferrous metals, alloys, composite materials and new type of material have been used in aircraft, optics, automobile, semiconductors, national defense and so on, those materials are need to be fine machined in which a lots of demands have been presented about cutting tools especial in precision and ultra-precision processing.

Diamond is very good for precision machining as cutting tools because of its excellent performances, such as highest rigidity, small friction coefficient, high heat guide, low heat expand coefficient and chemistry inertia. And also because of that, diamond is one of the materials that lapping and polishing difficult. It becomes a hotspot in science and engineering to make a high quality diamond surface such as in diamond tool processing.

Diamond finished surfaces mostly based on the mechanical lapping or polishing till now, owing to the merits of mechanical technology being mature, reliable and low cost. But to get a perfect diamond surface, especially in processing high quality diamond tool, it is very necessary to keep spindle steady and no vibration to avoid crack of knife-edge. It is considered that the polishing axial motion should be control less than $3\mu\text{m}^{[1]}$, otherwise a good diamond tools would be hard to make. In order to restrain the most vibration coming from spindle, some of bearing technology are developed and select in using.

(1) Aerostatic bearings

Aerostatic bearings can control the axial motion in $0.1\mu\text{m}$ or $0.01\mu\text{m}$, and are often used in ultra-precise diamond lapping & polishing. A fly in the ointment, devices using such bearings are usually cost high, complex because aerostatic bearings need air compressor, filter and other assistant devices, and need skillful operators to work it.

(2) Hydrostatic bearings

Hydrostatic bearing's rotary accuracy is also very

high, and spindle using Hydrostatic bearings can decline vibration, which is very suitable for low rotate speed system. But hydrostatic bearings are cost high and need complex hydraulic system which should take measures to prevent cooling fluid or dust entering into hydraulic circulating system, avoid the oil leakage.

(3) Hydrodynamic bearings

Hydrodynamic bearing make use of lubricities film which is produced by high speed rotating. It can support high pressure and resist vibration when it is working at high speed. Compared to hydrostatic bearing, hydrodynamic bearing system is more simple and easy to install and maintenance.

In this paper, in order to development a minitype of precise and reliable spindle system for diamond lapping, brushless DC (BLDC) spindle motors are adopted in which fluid dynamic bearings (FDB) are selected to use. The working speed in processing of diamond is high but the lapping load is low, to improve the diamond polishing condition.

2. Spindle of Lapping System

To make a precise compact of minitype spindle of lapping system, BLDC spindle motor is selected in this paper. The lapping finish table which is mainly made by a disk as shown in Fig.1, rotates against the diamond to be finished, and is driven direct by BLDC spindle motor. Other than usual used motors, the shaft used in this BLDC spindle motor system is fixed, the table rotates round the shaft for the sake of higher rigidity and improving spindle dynamic. As the key components of spindle, fluid dynamic bearings are adopted in the system, which function is performed by a thin layer of fluid, thinner than one-tenth the thickness of a human hair. And such a thin layer film of fluid separate the rotating parts from stationary of the bearing and greatly increases the anti-shock capability of the system. The oil film also act as an absorber, in which fluid provides mechanical damping and reduces the vibrate amplification, prevents from those exterior impact

* Sponsored by department of science and technology of Guangdong province (2003B12002)

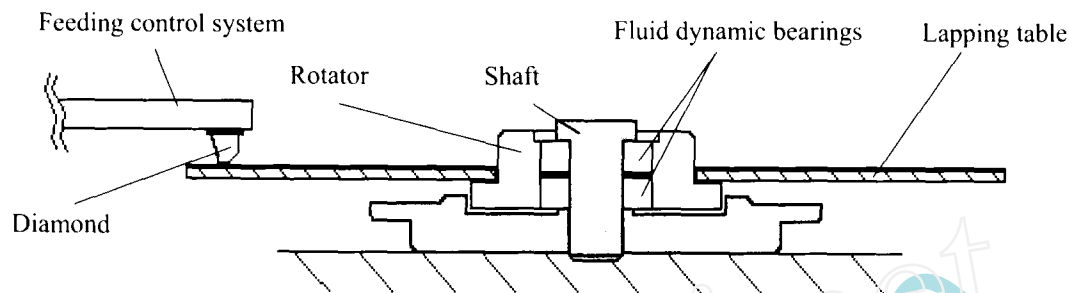

Figure 1 Diamond lapping system based on brushless DC motor spindle and fluid dynamic bearings

that great influence on the performance of diamond lapping, especially in diamond tool processing. Seagate's test^[2] shows that fluid dynamic bearings can endure 1500Gs impact, the ball bearing only 150Gs. Some special lubricant can be adopted to avoid oil leakage, and can make fluid dynamic bearing work more than 5 years without any maintenance.

Brushless DC spindle motors with fluid dynamic bearings has been used in hard disk largely, the technologies are very mature and reliable. It can provides axial motion controlled in $0.23\mu\text{m} \sim 1.2\mu\text{m}$ and the radial motion less than 100nm from the Lin Guo's test results^[3], at the same time it achieves higher speed and more reliable.

Including other advantages, such as configurations simple, no need of oil and air supply system, no need of special filter system, no need of much maintenance and cost low relatively, make the BLDC spindle motor be very suit for designing a minitype setup of diamond precise lapping and polishing.

3. Improvement for Dynamic Imbalance of Spindle System

The dynamic performances of designed minitype diamond lapping system are much affected by the imbalance of the spindle system. It needs to be elaborate installed, dynamic imbalance detected and adjusted to minimize the vibration of spindle system and make sure that the spindle system can work well for long time. The lapping table may be induced periodical vibration when the disk of lapped and polish is mounted on a spindle and to be rotated, if center of mass of disk is offset the center axis of rotation of the spindle and forms a centrifugal force. Because the centrifugal force is proportional to the square of the rotation frequency, the dynamic imbalance can not be ignored especial in high speed rotation spindle such as in the lapping conditions introduced in this paper, which may bring a micro impact to diamond surface to be finished. So, dynamic imbalance adjustment should be taken to decrease the amount of vibration caused by centrifugal force. In order to solve this problem in this paper, parallelogram method is used to detect the dynamic imbalance of the spindle. The process is taken by following: First, the disk is installed and make the

lapping table rotate; second, vibration of the spindle system is measured by vibration sensors, and from that the amount of imbalance including the position and the direction are calculated by using parallelogram method; third, a counterweight with a controlled mass is attached to an opposite side of that calculated imbalance fixed position. The balance adjusting operation may be repeated several times until the vibration produced by offset of disk within a tolerance. From the test results, the dynamic imbalance can be adjusted very well and vibration can be minimized to ensure the spindle working reasonably reliable.

4. Spindle Control System

Brushless DC spindle motor's configuration may be simple, as mentioned above, but the control system may be generally complexity because there need some servo control techniques. The servo control system of sensorless brushless DC motor for diamond precise lapping and polishing used in this paper, are including hardware and software. They all need to be considerate in designing, for example, design to start motor smoothly, to estimate rotor position, to commutate and so on should be deal with correctly, otherwise the motor can not work well. Figure 2 is a speed and current closed loop control system for brushless DC spindle motors used in the system, including the parts of driver circuit, servo control circuit and detecting circuit. The driver circuit is made up of inverter-switching devices, which control rotor to the correct position. The servo control circuit included speed control circuit and current control circuit. Speed control principle is: First, Servo control system detected Back EMF of BLDC motor and changed to motor's speed signal. Second, the speed signal is compared with the reference speed. Third, the system generated pulse widths modulation (PWM) signals to control the motor current. Speed controller and Logic control Unit corrected and adjust motor's speed. Current control principle is: First, current of motor is sampled. Second, current of motor is compared with the max current which is set by servo control system. Third, current will be changed by control PWM Duty Cycle.

IC controller is selected to use in designed servo control system for development a minitype diamond

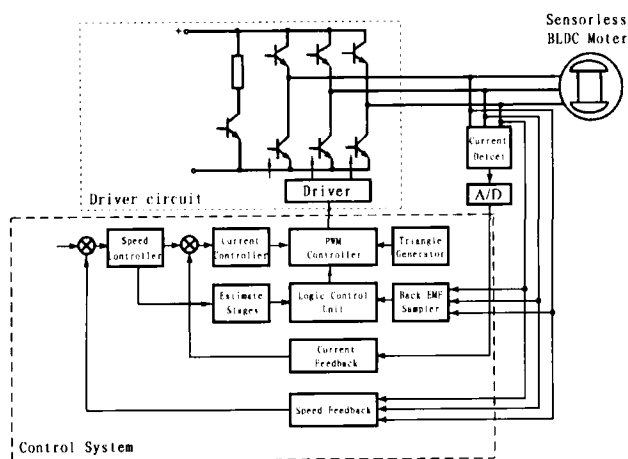

Figure 2. Closed-loop system of BLDC motor

lapping device, here. It can also be selected a single chip computer or DSP to use, which may provide servo control system powerful function, may improve motor performance by using some advanced control strategy and method like neural network, may make control flexible, high precision, but in generally the cost of them are high, the control may be complicated, and debug difficult. With comparing, the circuitry of IC controller is simple, debug is convenience, the control system is reliable and designed can be in short times. The control precision can also be comparatively high (when speed is higher than 2000r/min, error is less than 0.1%, and higher than 5000r/min, less than 0.02%, from Yang et al test result^[4]), which are suitable for the purpose in high speed and low pressure diamond lapping.

The type of ML4426 controller is selected in this

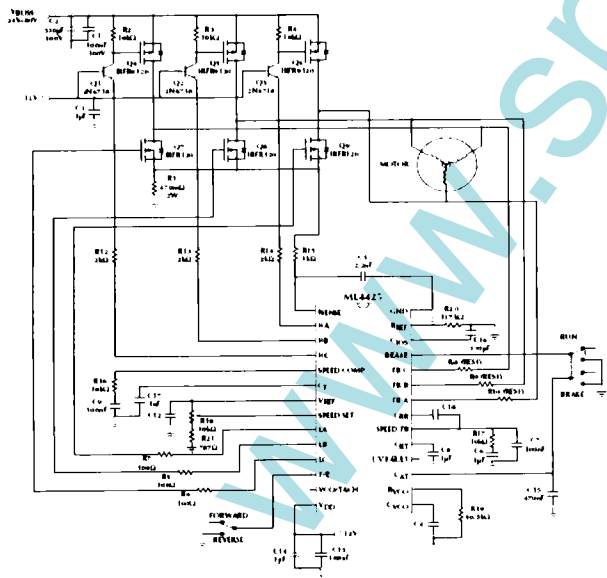

Figure 3. Control circuit of BLDC motor^[5]

paper, which provides all of the functions necessary for starting and controlling the speed of delta or wye wound sensorless brushless DC motors. It is made up by Voltage Controlled Oscillator (VCO), PWM Speed Control, High

Side Drive Output, Low Side Drive Output, Back EMF Sensing PLL Commutation control, Back EMF Sampler and so on. This IC controller provides speed and current closed loop control, PWM speed control, forward/reverse operation. The motor start-up is comprised of three modes: align mode, ramp mode, run mode. Figure 3 is a control circuit of Brushless DC spindle motors. Which it make up of ML4426, six power MOSFETs and some peripheral circuit which included some capacitances, resistances and dynatrons.

When design control circuit of align mode and ramp mode, some problems must be noticed. Because the parameters are set irrationally, the motor can not start-up and work. The align mode time is set by a capacitor connected to the C_{AT} pin. The actual capacitance is decided by parameters of motor and load. The capacitance is more, position time needs more, and the motor can more reliable to position. But at the same time, it will increase times of position.

During ramp mode, the amount of time staying in ramp mode is determined by a capacitor connected to the C_{RT} pin, and the rate at ramping up the motor speed is determined by a capacitor connected to C_{RR} pin. The actual capacitance of C_{RT} and C_{RR} are also decided by parameters of motor and load. If motor start-up can not go to run mode, then increase C_{RT} until the motor can go to run mode.

For speed control, ML4426 provide PWM closed loop speed control. Speed control is accomplished by setting a speed command at SPEED SET pin with input voltage from 0 to 6.9V (V_{REF}), this voltage is controlled from resistance or microcontroller. This paper used a precise resistance to control motor speed. The accuracy of the speed command is determined by the external components R_{VCO} and C_{VCO} . The capacitance C_{VCO} decided VCO maximum frequency and speed range. The less value of capacitance, the minimum speed is less and the maximum speed is higher, speed range is larger.

This paper adopt Sensorless BLDC spindle motors which maximum speed is 5400r/min and standard voltage is +12V. The control system is make up of one ML4426, six power MOSFETs and the external circuit. Now the motor can long term reliable work without any maintenance. The speed of motor can be adjusted between 1200r/min and 5400r/min.

5. Experiment

5.1 Experiment condition

Experiments have been done by using the developed minitype precise diamond lapping and polishing setup described above. Diamond single crystals are used to be finished in the experiment, and the crystallographic orientation of diamond is estimated by eye, (100) surface of octahedron diamond is chose to polish. Machining parameters are: spindle speed in 3600r/min, pressure in 0.5N and provided by spring. Same experiments have been done several times.

Result of experiment is observed by Metallurgical Microscope and AFM, the surface roughness are also measured by AFM. AFM is made by Chinese Academy

of Sciencer, model CSPM-2003, lateral resolution is 0.26nm and vertical resolution is 0.1nm.

5.2 Result of experiment

Lapping diamond tool is one of the tough works, because the knife-edge is easy affect by impact and vibration of spindle, and there are several other requests concerning crystallographic orientation, blade sharpness, surface roughness and edge geometrical accuracy. Lapping and polishing of diamond in ordinary condition, defects and knife-edge collapse are easy observed, which show at figure 4, a photo taken by metallographic microscope, it indicates the knife-edge is not prefect and there are some defect in the edge area which may be produced by vibration of spindle sysetm. Compared with that, Figure 5 shows one of the diamond finished results which are lapping and polishing by using the developed spindle system. The arrow head denotes the lapping directions, and from the metallographic microscope photo, it indicates that the diamond surface is smooth, no process trace and cleavage. The knife-edge shows no defect as shown in Fig 4. Details correspond to the results above, investigated farther by AFM, are shown in Fig. 6, which also reveals that no defeat and process trace are found. AFM test result shows that diamond edge's Ra is about 6.725nm and whole diamond average Ra is 3.25nm. All experimental results reveal that the spindle system is very stabilization which can make high quality diamond surfaces.

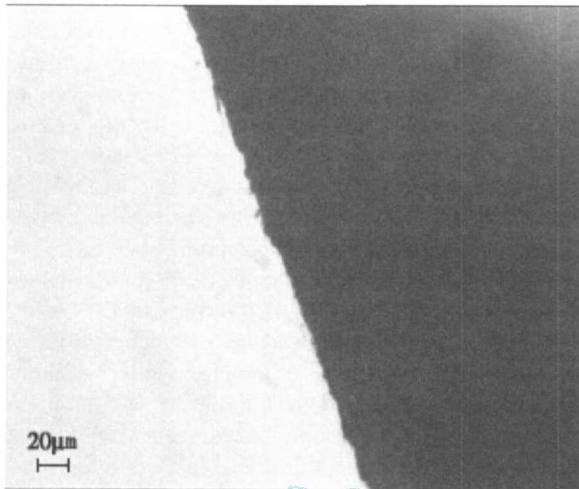

Figure 4. Collapse happened in knife-edge

6. Conclusions

A minitype precise spindle system for diamond lapping and polishing has been designed, which adopt sensorless brushless DC motor as spindle. From the test result, the spindle system can suppress the vibration efficaciously and improve stability of Lapping & Polishing Machine, can improve the quality of diamond tools.

References

[1] Li Shuyan and Li XianMing, Study on the Finishing Equipment and Technology for Diamond Tools, Tool Engineering., 31(3),1997:09-12 (in Chinese)

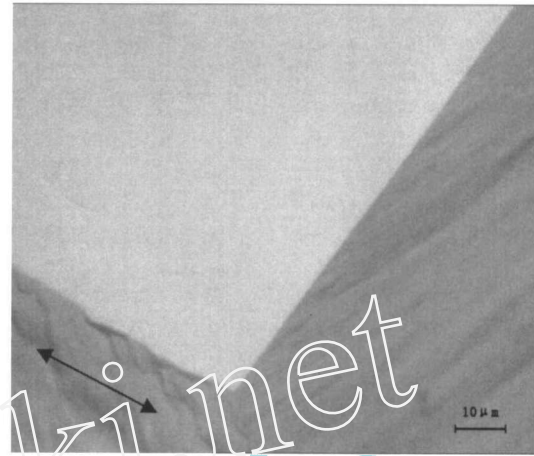

Figure 5. Diamond surface lapped by developed spindle system

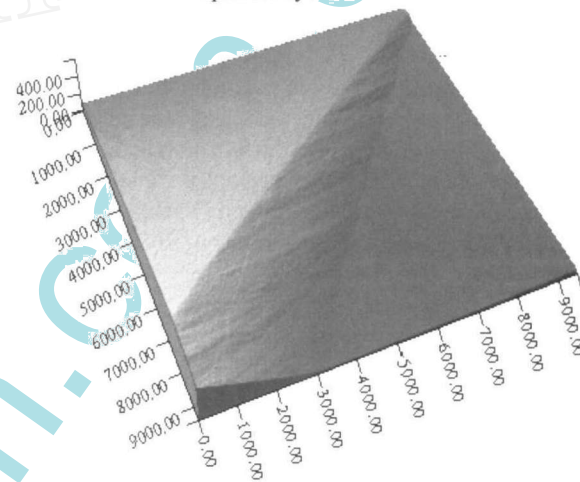

Figure 6. Diamond surface scan by AFM

[2] Seagate, Using FDB motor: high revolutions, low noise, Electronic Products, 3,2001:19-20(in Chinese)

[3] Lin Guo, and Yih-Jen Dennis Chen, Disk Flutter and Its Impact on HDD Servo Performance, IEEE Transactions on Magnetics, 37(2), 2001: 866-870(in Chinese)

[4]Yang ZhiBin et al, Speed Control of Electro-magnetic Planar Micromotor Based on ML4426, SERVO TECHNIQUE,06, 2004: 37-46

[5]Micro Linear, Bi-directional Sensorless BLDC Motor Controller, 2000

Contact info:

Fu HuiNan
Professor
Department of Mechanical Engineering
Guangdong University of Technology
Guangdong, Guang0zhou,510090 China
Phone:86-20-37627602 Fax:86-20-37627005
Email:hfnfu@gdut.edu.cn
Website:http://imt.gdut.edu.cn